



LM136-2.5/LM236-2.5/LM336-2.5V Reference Diode

General Description

The LM136-2.5/LM236-2.5 and LM336-2.5 integrated circuits are precision 2.5V shunt regulator diodes. These monolithic IC voltage references operate as a low-temperature-coefficient 2.5V zener with 0.2Ω dynamic impedance. A third terminal on the LM136-2.5 allows the reference voltage and temperature coefficient to be trimmed easily.

The LM136-2.5 series is useful as a precision 2.5V low voltage reference for digital voltmeters, power supplies or op amp circuitry. The 2.5V make it convenient to obtain a stable reference from 5V logic supplies. Further, since the LM136-2.5 operates as a shunt regulator, it can be used as either a positive or negative voltage reference.

The LM136-2.5 is rated for operation over -55°C to +125°C while the LM236-2.5 is rated over a -25°C to +85°C temperature range.

The LM336-2.5 is rated for operation over a 0°C to +70°C temperature range. See the connection diagrams for available packages.

Features

- Low temperature coefficient
- Wide operating current of 400 μA to 10 mA
- 0.2Ω dynamic impedance
- ±1% initial tolerance available
- Guaranteed temperature stability
- Easily trimmed for minimum temperature drift
- Fast turn-on

Connection Diagrams

TO-92
Plastic Package

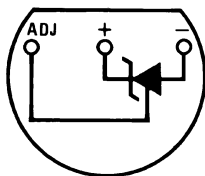

00571508

Bottom View

Order Number LM336Z-2.5 or LM336BZ-2.5
See NS Package Number Z03A

TO-46
Metal Can Package

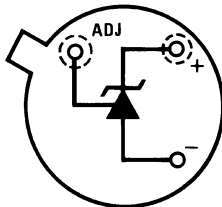

00571520

Bottom View

Order Number LM136H-2.5,
LM136H-2.5/883, LM236H-2.5,
or LM236AH-2.5
See NS Package Number H03H

SO Package

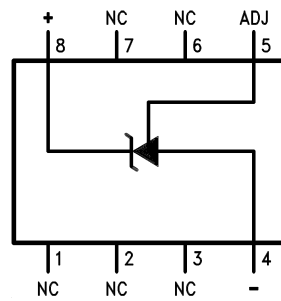

00571512

Top View

Order Number LM236M-2.5,
LM236AM-2.5, LM336M-2.5
or LM336BM-2.5
See NS Package Number M08A

Typical Applications

2.5V Reference

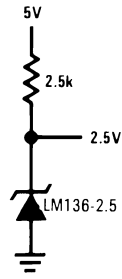

00571509

Wide Input Range Reference

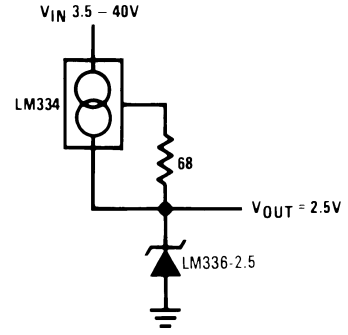

00571511

2.5V Reference with Minimum Temperature Coefficient

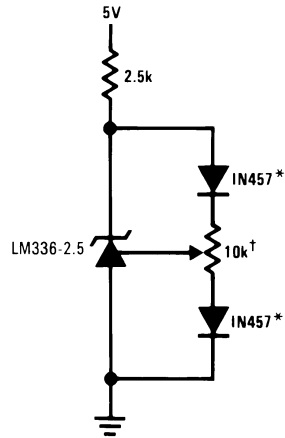

00571510

† Adjust to 2.490V

* Any silicon signal diode

Absolute Maximum Ratings (Note 1)

If Military/Aerospace specified devices are required, please contact the National Semiconductor Sales Office/Distributors for availability and specifications.

Reverse Current	15 mA
Forward Current	10 mA
Storage Temperature	-60°C to +150°C
Operating Temperature Range (Note 2)	
LM136	-55°C to +150°C
LM236	-25°C to +85°C

LM336 0°C to +70°C

Soldering Information

TO-92 Package (10 sec.)	260°C
TO-46 Package (10 sec.)	300°C
SO Package	
Vapor Phase (60 sec.)	215°C
Infrared (15 sec.)	220°C

See AN-450 "Surface Mounting Methods and Their Effect on Product Reliability" (Appendix D) for other methods of soldering surface mount devices.

Electrical Characteristics (Note 3)

Parameter	Conditions	LM136A-2.5/LM236A-2.5			LM336B-2.5			Units
		LM136-2.5/LM236-2.5			LM336-2.5			
		Min	Typ	Max	Min	Typ	Max	
Reverse Breakdown Voltage	$T_A=25^\circ\text{C}$, $I_R=1\text{ mA}$							
	LM136, LM236, LM336	2.440	2.490	2.540	2.390	2.490	2.590	V
	LM136A, LM236A, LM336B	2.465	2.490	2.515	2.440	2.490	2.540	V
Reverse Breakdown Change With Current	$T_A=25^\circ\text{C}$, $400\ \mu\text{A} \leq I_R \leq 10\text{ mA}$		2.6	6		2.6	10	mV
Reverse Dynamic Impedance	$T_A=25^\circ\text{C}$, $I_R=1\text{ mA}$, $f = 100\text{ Hz}$		0.2	0.6		0.2	1	Ω
Temperature Stability (Note 4)	V_R Adjusted to 2.490V $I_R=1\text{ mA}$, Figure 2 $0^\circ\text{C} \leq T_A \leq 70^\circ\text{C}$ (LM336)					1.8	6	mV
	$-25^\circ\text{C} \leq T_A \leq +85^\circ\text{C}$ (LM236H, LM236Z)		3.5	9				mV
	$-25^\circ\text{C} \leq T_A \leq +85^\circ\text{C}$ (LM236M)		7.5	18				mV
	$-55^\circ\text{C} \leq T_A \leq +125^\circ\text{C}$ (LM136)		12	18				mV
Reverse Breakdown Change With Current	$400\ \mu\text{A} \leq I_R \leq 10\text{ mA}$		3	10		3	12	mV
Reverse Dynamic Impedance	$I_R=1\text{ mA}$		0.4	1		0.4	1.4	Ω
Long Term Stability	$T_A=25^\circ\text{C} \pm 0.1^\circ\text{C}$, $I_R=1\text{ mA}$, $t = 1000\text{ hrs}$		20			20		ppm

Note 1: Absolute Maximum Ratings indicate limits beyond which damage to the device may occur. Electrical specifications do not apply when operating the device beyond its specified operating conditions.

Note 2: For elevated temperature operation, T_j max is:

LM136	150°C
LM236	125°C
LM336	100°C

Thermal Resistance	TO-92	TO-46	SO-8
θ_{ja} (Junction to Ambient)	180°C/W (0.4" leads) 170°C/W (0.125" lead)	440°C/W	165°C/W
θ_{ja} (Junction to Case)	n/a	80°C/W	n/a

Physical Dimensions inches (millimeters)

unless otherwise noted

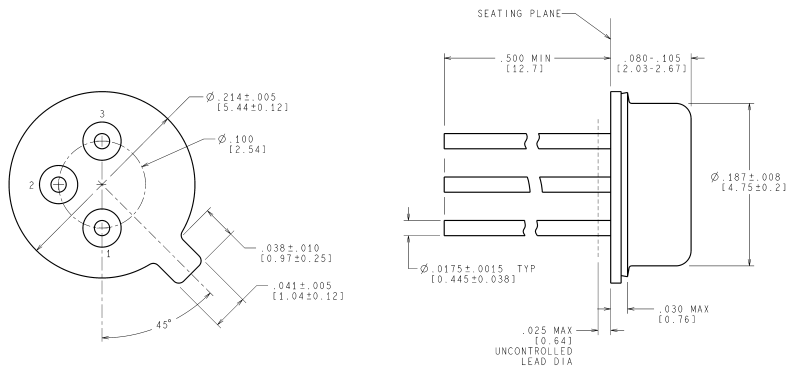

CONTROLLING DIMENSION IS INCH
VALUES IN [] ARE IN MILLIMETERS

H03H (Rev F)

Order Number LM136H-2.5, LM136H-2.5/883, LM236H-2.5, LM136AH-2.5, LM136AH-2.5/883 or LM236AH-2.5
NS Package Number H03H

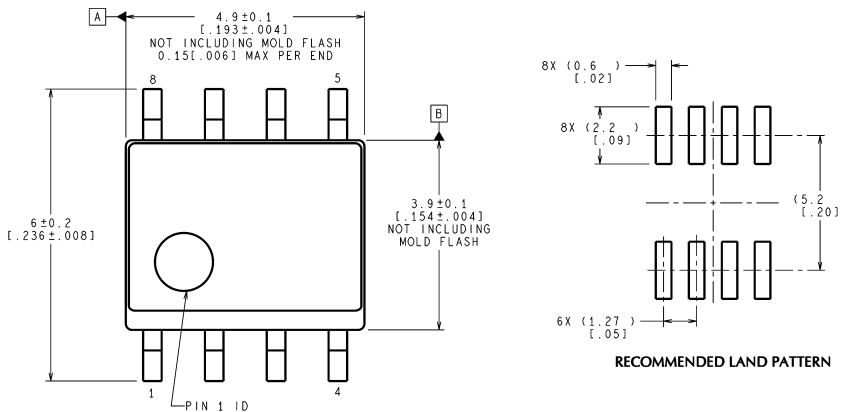

RECOMMENDED LAND PATTERN

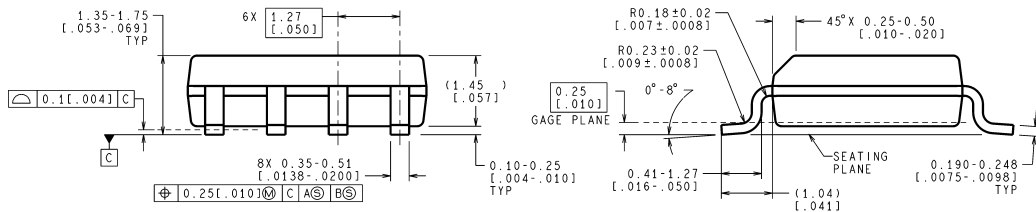

CONTROLLING DIMENSION IS MILLIMETER
VALUES IN [] ARE INCHES
DIMENSIONS IN () FOR REFERENCE ONLY

M08A (Rev K)

Small Outline (SO) Package (M)
Order Number LM236M-2.5, LM236AM-2.5, LM336M-2.5 or LM336BM-2.5
NS Package Number M08A